



Figure 1 Physical photo of TEC5V4A-D

FEATURES

- High Efficiency: $\geq 90\%$
- Maximum Output Current: 4A
- Maximum Output Voltage: VPS – 0.2V
- Actual Object Temperature Monitoring
- High Stability: 0.01°C
- High Precision
- High Reliability
- Zero EMI
- Compact Size

DESCRIPTION

The TEC5V4A-D is an electronic module designed for driving TECs (Thermo-Electric Coolers) with high stability in regulating the object temperature, high energy efficiency, zero EMI, and small package. Figure 1 is the photo of an actual TEC5V4A-D.

The module provides interface components for users to configure desired object temperature range, i.e. set-point temperature range ; maximum voltage across TEC, i.e. maximum TEC voltage; and the compensation network. The

compensation network compensates the high order thermal load and thus stabilizes the temperature control loop.

It provides these functions: thermistor T-R curve linearization, temperature measurement and monitoring, temperature control loop status indication, TEC voltage monitoring, power up delay, and shut down.

The TEC5V4A-D comes with a high stability low noise 3.0V voltage reference which can be used for setting the desired object temperature by using a POT (Potentiometer) or a DAC (Digital to Analog Converter). When using this reference for setting the set-point temperature, the set-point temperature error is independent of this reference voltage. This is because the internal temperature measurement network also uses this voltage as the reference, the errors in setting the temperature and measuring the temperature cancel with each other, setting the object temperature with higher stability. This reference can also be utilized by an ADC (Analog to Digital Converter), for the same reason, the measurement error will also be independent of the reference voltage, resulting in a more accurate measurement.

Figure 1 is the photo of the actual TEC5V4A-D controller. Figure 2 is the real size top view of the controller showing the pin names and locations with the actual size. TECA1 pin functions are shown in Table 1.

The TEC5V4A-D is packaged in a 6 sided metal enclosure, which blocks EMIs (Electro-Magnetic Interferences) to prevent the controller and other electronics from interfering with each other.

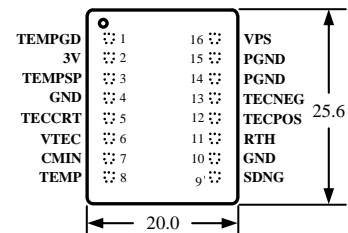

Figure 2 Pin names and locations

SPECIFICATIONS

Table 1 Pin Function Descriptions

Pin #	Pin Name	Type	Description
1	TEMPGD	Digital output	Temperature good indication. It is pulled high when the set-point temperature and the actual desired object temperature are $<0.1^{\circ}\text{C}$ in temperature difference when the set-point temperature range is 20°C ; or $<3\text{mV}$ in voltage difference between the voltages of TEMP and TEMPSP nodes. On this pin, there is an internal pull up resistor of 10K tied to the VPS rail. When going low, this pin is pulled down by an open drain FET with a resistance of 250Ω @ $\text{VPS} = 5\text{V}$.
2	3VR	Analog output	Reference voltage output, 3V . It can be used by a POT or DAC for setting the set-point temperature voltage on the TEMPSP pin and/or a DAC for measuring the temperature through the TEMP pin. The maximum sourcing current capability is 1.5mA and the maximum sinking is 4mA with a stability of $<50\text{ppm}/^{\circ}\text{C}$ max.
3	TEMPSP	Analog input	Object set-point temperature input port. It is internally tied by a 50K resistor to the half value of the reference voltage, 1.5V . The open circuit voltage of this pin is thus 1.5V , corresponding to a set-point temperature of 25°C by using the default temperature network (with the set-point temperature range being from 15°C to 35°C). It is highly recommended to set this pin's voltage by using the controller's voltage reference. The lower limit of the setting voltage for this pin is 0.1V . Setting this pin to a $<0.1\text{V}$ voltage may cause the controller over cooling the object. This pin can also be set to a voltage that is about 0.2V away from the VPS rail. For example, when $\text{VPS} = 5\text{V}$, this pin can be set up to 4.8V , corresponding to approximately 50C in temperature when the default temperature network is in place, see the curve shown in Figure 6. This pin can be set by using a POT or DAC. When the set-point temperature needs to be at 25°C , leave this pin unconnected.
4	GND	Ground	Signal ground for the POT, ADC, DAC and the thermistor, see Figure 4.
5	TECCN	Both analog input and output	TEC control voltage. It can be left unconnected or used to control the TEC voltage directly. Set TECCRT between 0V to VPS , the voltage across TEC will be: TEC voltage = $\text{VPS} - 2 \times \text{TECCRT}$. It can also be used to configure the maximum voltage cross the TEC: Max. TEC voltage = $\text{VPS} \times \text{Rm} / (\text{Rm} + 10\text{K})$, where Rm is the resistance of the two resistors one between TECCRT to GND and the other between TECCRT to VPS, see Figure 4.
6	VTEC	Analog output	TEC voltage indication. TEC voltage = $[\text{max. TEC voltage}] \times [\text{VPS} - 2 \times \text{VTEC}] / \text{VPS}$. When TECCRT is used to control the TEC voltage directly, measure TECCRT to derive the TEC voltage instead, and use this formula: TEC voltage = $\text{VPS} - 2 \times \text{TECCRT}$. The maximum driving current of pin VTEC is 30mA and the output voltage swing is 0V to VPS .
7	CMIN	Analog input	Compensation input pin for the thermal control loop. Leave it open in production. When prototyping, use this pin with a tuner on the evaluation board, TECEV104 (produced by ATI) to tune the compensation network to match the characteristics of the thermal load.
8	TEMP	Analog output	Actual object temperature. It swings from 0V to VPS , corresponds to 15°C to 50°C when VPS equals to 5V . See the curve below.
9	SDNG	Digital input	Shut down control. When pulled low, it shuts down the controller. Leave it open or pull it high to activate the controller. This pin is internal pull up by a resistor of 100K to VPS .
10	GND	ground	Signal ground, internally connected to Pin 4 GND. Can be used for connecting the thermistor
11	RTH	Analog input	Connect to the thermistor for sensing the desired object temp. Thermistor's other end connects to the signal ground, pin 4 or pin 10. $\text{Rth} = 10\text{K}\Omega$ @ 25°C . Other thermistors or temperature sensors can also be used, consult with us.

12	TECPOS	Analog power output	Connects to TEC positive terminal
13	TECNEG	Analog power output	Connects to TEC negative terminal
14	PGND	Power ground	Power ground for connecting to the power supply
15	PGND	Power ground	Power ground for connecting to the power supply, internally connected with pin 14
16	VPS	Power input	Positive power supply rail. The value is 5V.

Table 2 Characteristics ($T_{\text{ambient}}=25^{\circ}\text{C}$)

Parameter	Test Condition	Value	Unit/Note
Object* temp. stability vs. ambient temp	$VPS=5V, R_{\text{load}}=1.2\Omega$	0.0002	$^{\circ}\text{C}/^{\circ}\text{C}$
Object temp. vs. set-point. offset	T_{ambient} is $0 \sim 50^{\circ}\text{C}$, set-point temp. is $15^{\circ}\text{C} \sim 35^{\circ}\text{C}$	± 0.1	$^{\circ}\text{C}$
Object temp. response time	≤ 0.1 to the set-point temperature at a 1°C step	$< 5\text{S}$	S
Efficiency	$VPS=5V, R_{\text{load}}=1.2\Omega$	$\geq 90\%$	-
Max. output current	$VPS=5V, R_{\text{load}}=1.2\Omega$	4	A
Max. output voltage	$VPS=5V, R_{\text{load}}=1.2\Omega$	$0 \sim (VPS-0.2)$	V
Power supply voltage	—	$4.75 \sim 5.25$ (specify 5)	V
Set-point temp.** control voltage	$VPS=5V, R_{\text{load}}=1.2\Omega$	$0.1 \sim VPS$	V
Default set-point temp. range***	$VPS=3V$	$15 \sim 35$	$^{\circ}\text{C}$
Operating ambient temp. range	$VPS=5V, R_{\text{load}}=1.2\Omega$	$-25 \sim 85$	$^{\circ}\text{C}$

* Object temperature refers to the actual cold side temperature of the TEC, on where the target is mounted.

** Set-point temperature is the temperature desired to have on the target.

*** Can be customized to any range according to requirement.

BLOCK DIAGRAM

The block diagram of the controller is shown in Figure 3.

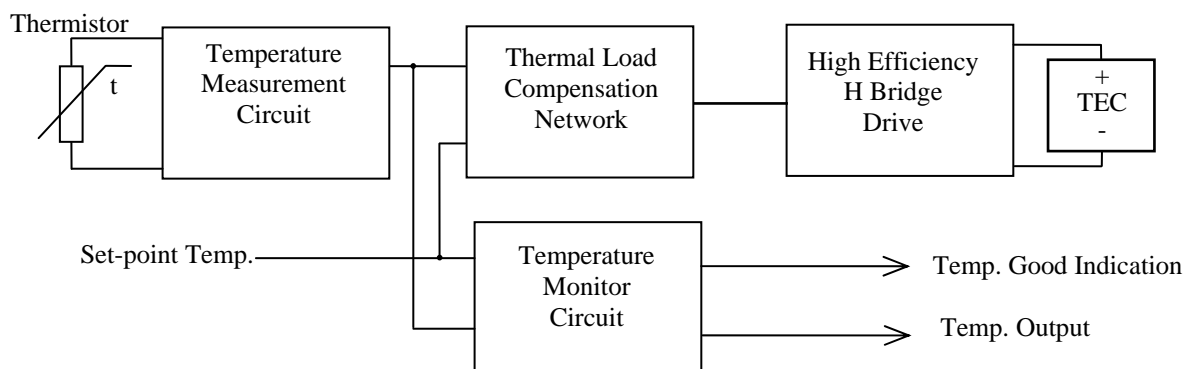

Figure 3 TEC Controller Block Diagram

APPLICATIONS

TEC controller connections are shown in Figure 4.

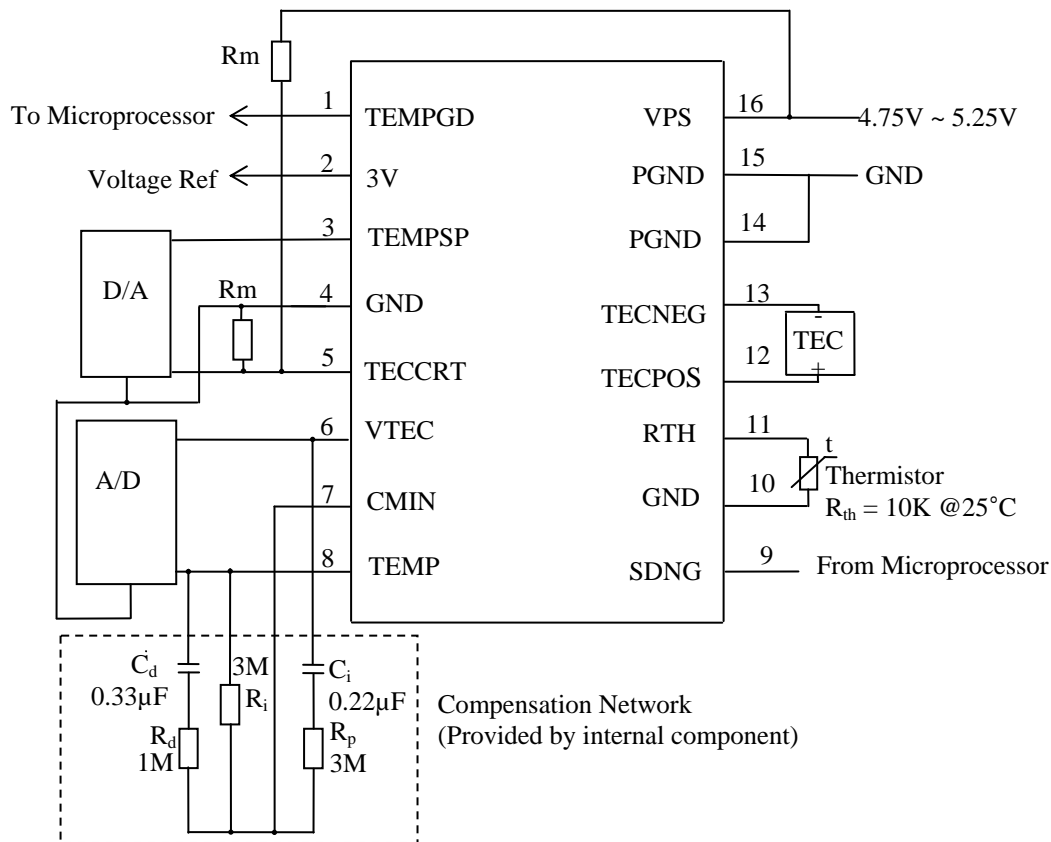

Figure 4 TEC controller connections

If you want to use this TEC controller for other applications not discussed here, such as use it with wave locker controllers, please consult with us. The same as to other customizations, such as setting the **TEMPSP** by using a voltage source swings above 3V and/or VPS.

The TECA1 controller comes with a default temperature setting network, it sets the set-point temperature to be between 15°C to 35°C when setting the **TEMPSP** pin voltage to be between 0V to 3V linearly and using a specific de-facto “standard” 10K @ 25°C thermistor, with its R-T value data listed in Figure 6. When using different thermistors and/or needing different set-point temperature ranges, please contact us, we will configure the internal temperature network for you.

TYPICAL CHARACTERISTICS

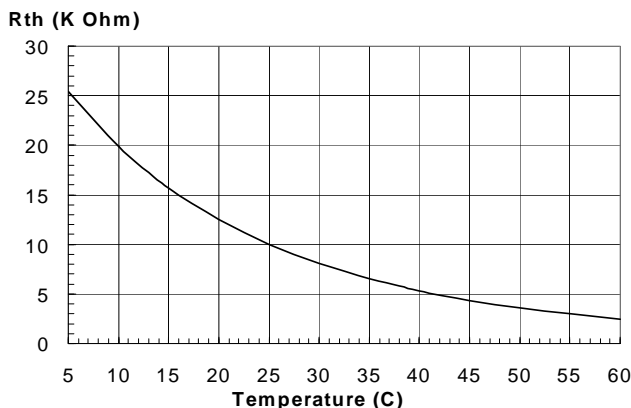

Figure 5 Rth vs. Temperature

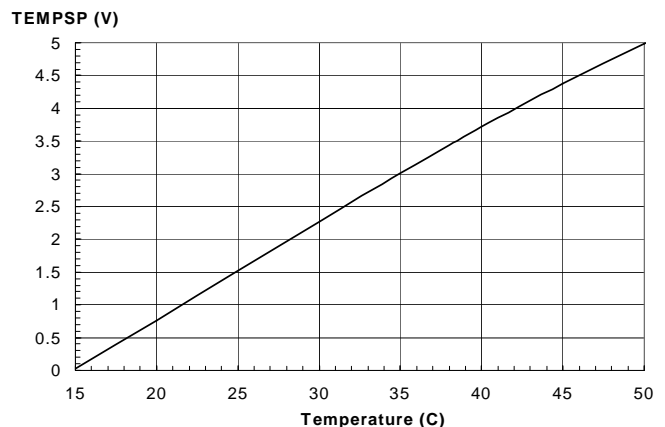

Figure 6 TEMPSP vs. Temperature

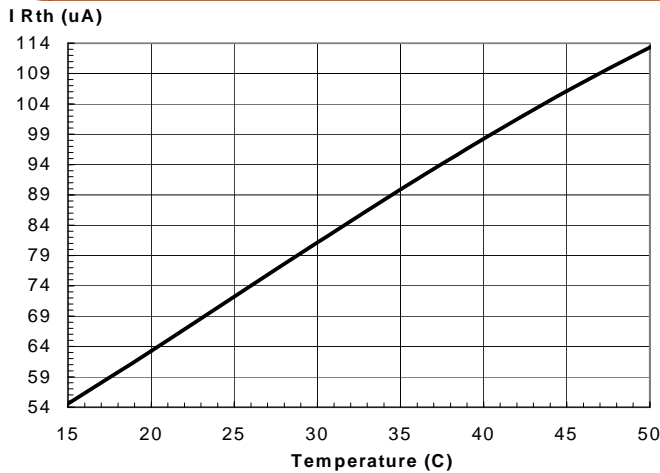

Figure 7 I_{Rth} vs. Temperature

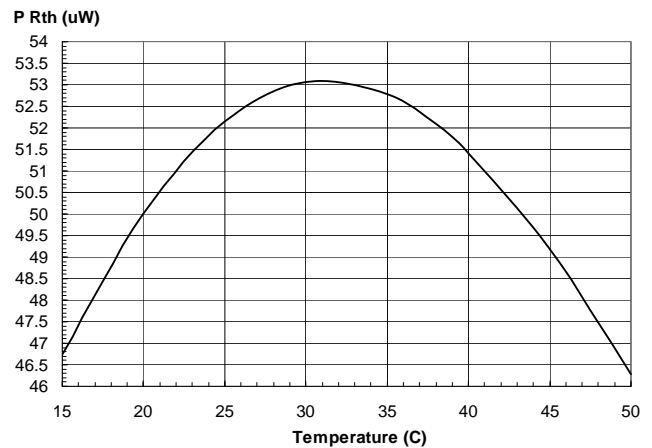

Figure 9 P_{Rth} vs. Temperature

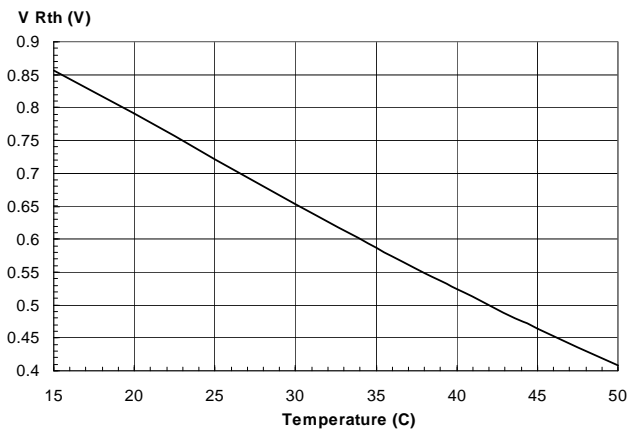

Figure 8 V_{Rth} vs. Temperature

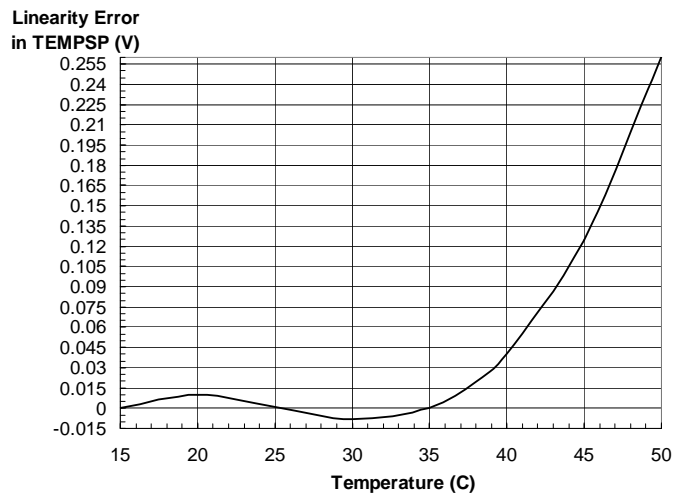

Figure 10 Linearity error in TEMPSP vs. Temperature

MECHANICAL DIMENSIONS

The controller comes in only one package: through hole mount. It is often called DIP (Dual Inline package) or D (short for DIP) package and has a part number: TEC4A5V-D. Dimensions of the DIP package controller is shown in Figure 11.

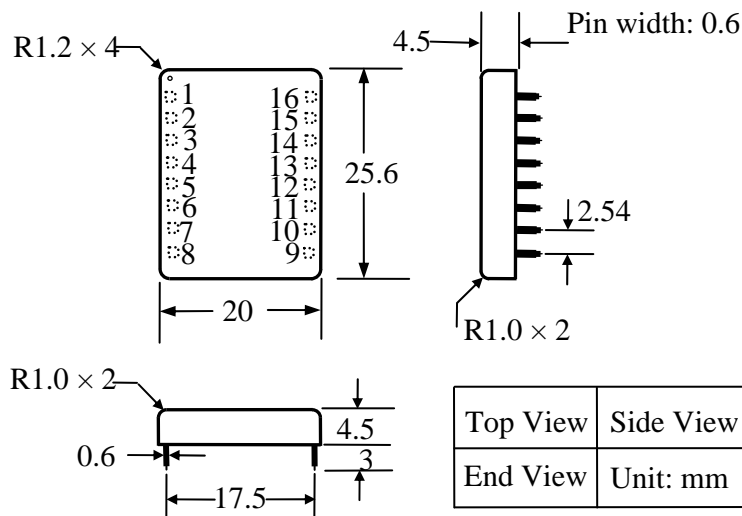

Figure 11 Dimensions of the DIP package controller of TEC4A5V-D

CUSTOMIZATIONS

It is often found that some of the default specifications do not meet our users' particular needs. We offer customizations on these specifications:

1. Maximum output voltage across TEC. When ordering, the part number will become: TEC-4A-5V-XV-D. E.g., TEC-4A-5V-4V-D
2. Set-point temperature range. When ordering, specify the lower limit, the upper limit, and the open circuit temperature. The part number will become: TEC-4A-5V-2.5V- (lower temp. limit)/(upper temp. limit)/(open circuit temp.), where lower temp. limit is the temperature corresponding to **TEMPSP** = 0V; upper temp. limit is the corresponding to **TEMPSP** = 3V; open circuit temp. corresponding to **TEMPSP** = 1.5V or being left unconnected. E.g., TEC-4A-5V-4V-D (20/80/50).
3. Asymmetrical maximum TEC voltage. The maximum TEC voltage for heating and cooling are not the same. When ordering, the part number will become: TEC-4A-5V- (max. TEC voltage for cooling/Max. TEC voltage for heating). E.g., TEC-4A-5V-2.5V/1.5V-D.

ORDERING INFORMATION

Table 3 Part Number

Part Number	Description	Note
TEC-4A-5V-XV*-D	5V power supply in DIP package with internal net.	Maximum output voltage across TEC should be selected 4.8V, when the output current reaches the max value-4A.

*XV stands for the maximum output voltage across TEC.

*4.8V means: when the current reaches the maximum value, the maximum output voltage = $VPS - 0.05 \times 4 = 5 - 0.2 = 4.8V$.

NOTICE

1. ATI warrants performance of its products for one year to the specifications applicable at the time of sale, except for those being damaged by excessive abuse. Products found not meeting the specifications within one year from the date of sale can be exchanged free of charge.
2. ATI reserves the right to make changes to its products or to discontinue any product or service without notice, and advise customers to obtain the latest version of relevant information to verify, before placing orders, that information being relied on is current and complete.
3. All products are sold subject to the terms and conditions of sale supplied at the time of order acknowledgment, including those pertaining to warranty, patent infringement, and limitation of liability. Testing and other quality control techniques are utilized to the extent ATI deems necessary to support this warranty. Specific testing of all parameters of each device is not necessarily performed, except those mandated by government requirements.
4. Customers are responsible for their applications using ATI components. In order to minimize risks associated with the customers' applications, adequate design and operating safeguards must be provided by the customers to minimize inherent or procedural hazards. ATI assumes no liability for applications assistance or customer product design.
5. ATI does not warrant or represent that any license, either express or implied, is granted under any patent right, copyright, mask work right, or other intellectual property right of ATI covering or relating to any combination, machine, or process in which such products or services might be or are used. ATI's publication of information regarding any third party's products or services does not constitute ATI's approval, warranty or endorsement thereof.
6. IP (Intellectual Property) Ownership: ATI retains the ownership of full rights for special technologies and/or techniques embedded in its products, the designs for mechanics, optics, plus all modifications, improvements, and inventions made by ATI for its products and/or projects.
7. After many experiments, according to the parameter and the figuring method of R_{load} , we advice customers to use R_{load} of 1.2Ω.